

# Acoustics

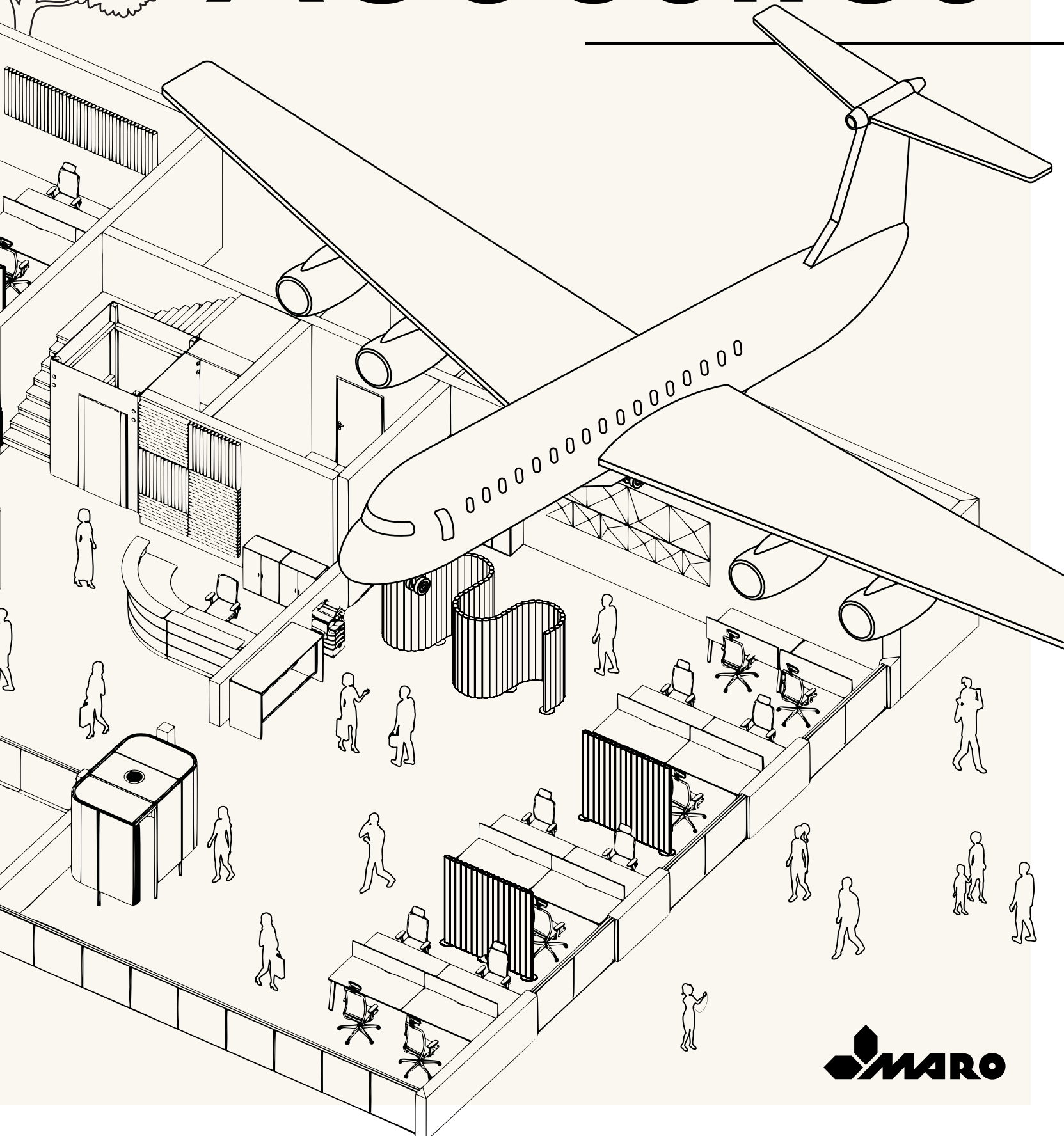

# Information library

## Information library



B2B Platform



**Order MARO products on our B2B platform!**

Zamów produkty MARO na naszej platformie B2B.

Bestellen Sie direkt über unsere B2B-Plattform!

Commandez les produits MARO sur notre plateforme B2B.



Photobank



**Download all the necessary materials from our base.**

Pobierz wszystkie potrzebne materiały z naszej bazy!

Hier finden Sie Materialien zum Download.

Téléchargez tout le matériel dont vous avez besoin à partir de notre base de données !

**pCon** pCon



**Start your adventure with a professional interior design tool.**

Już dziś zacznij przygodę z profesjonalnym narzędziem do projektowania wnętrza.

Starten Sie ins Abenteuer mit dem professionellen Raumplaner.

Commencez dès aujourd'hui votre aventure avec un outil professionnel d'aménagement des intérieurs.



Website



**Visit our website to stay up to date!**

Odwiedź naszą stronę i bądź na bieżąco.

Auf dem Laufenden bleiben? Besuchen Sie uns online!

Visitez notre site web et restez à jour.



Order samples



**Fill in the form and order samples from our latest color scheme.**

Wypełnij formularz i zamów próbki z aktualnego wzornika kolorystycznego.

Füllen Sie das Formular aus und bestellen Sie Muster aus unserer aktuellen Farbkarte.

Remplissez le formulaire et commandez des échantillons du nuancier actuel.



Consultation with our architect



**We will draw up a projection with an office design tailored to your needs.**

Przygotujemy dla Ciebie rzut z aranżacją według Twoich potrzeb.

Wir erstellen für Sie ein Bürokonzept ganz nach Ihren Bedürfnissen.

Nous préparerons pour vous une présentation avec l'aménagement adapté à vos besoins.

# Studio Rygalik



**EN** | Studio Rygalik represents and promotes a sensible, holistic approach towards design, materiality, sustainability and responsible consumption, developing a wide variety of comprehensive projects. The focus is on products and spaces.

**PL** | Studio Rygalik reprezentuje oraz propaguje świadomy i holistyczny sposób myślenia o projektowaniu, kulturze materialnej, zrównoważonym rozwoju i odpowiedzialnej konsumpcji, realizując szeroką gamę kompleksowych projektów, ze szczególnym naciskiem na produkty i wnętrza.

**DE** | Studio Rygalik vertritt und fördert einen bewussten, holistischen Ansatz in Bezug auf Design, materielle Kultur, Nachhaltigkeit und verantwortungsbewussten Konsum und realisiert in diesem Sinne vielfältige, umfassende Projekte, mit einem besonderen Schwerpunkt auf Produkten und Innenräumen.

**FR** | Le Studio Rygalik représente et promeut une manière consciente et holistique de penser au design, à la culture matérielle, au développement durable et à la consommation responsable, en réalisant une large gamme de projets complets, avec un accent particulier sur les produits et les intérieurs.

# Acoustics

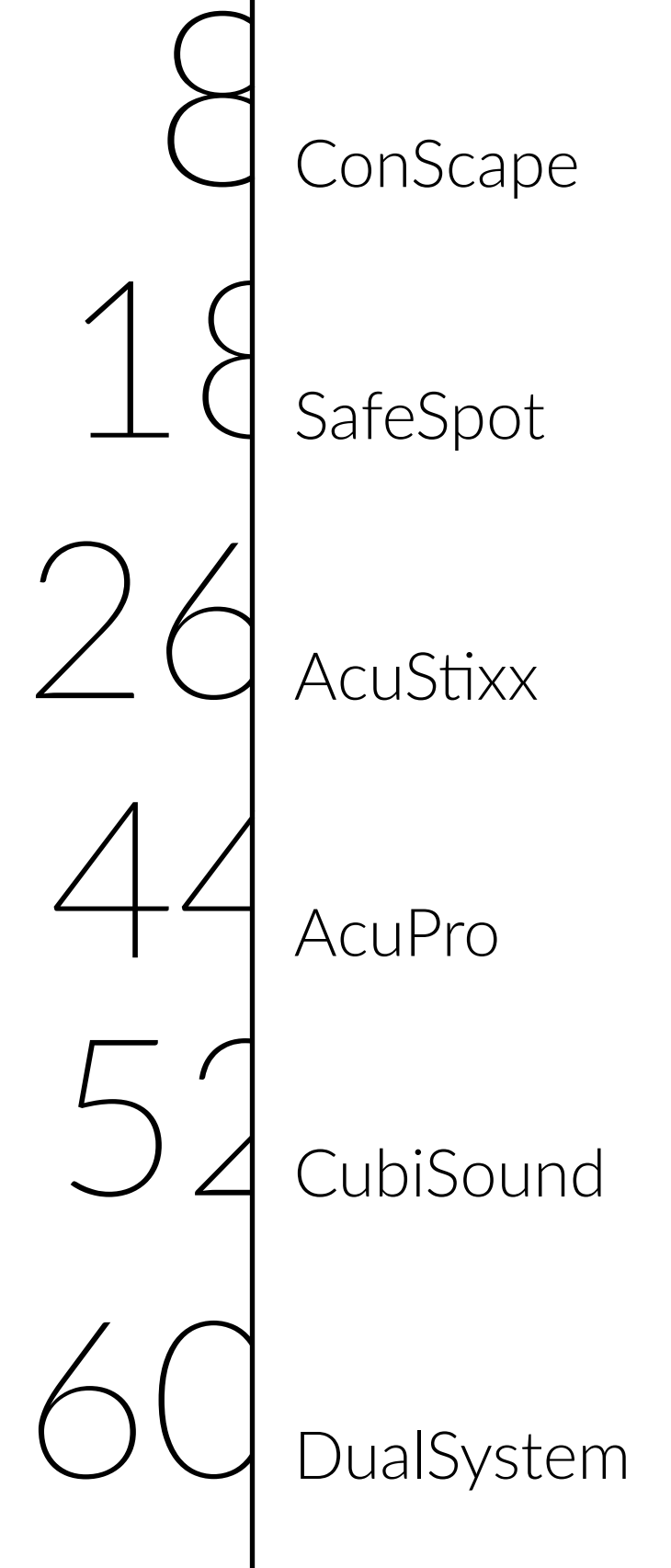

EN | ConScape constitutes a space division system that allows you to separate a private area needed for work in concentration. The design process put emphasis not only on a durable structure, but also the use of sustainable materials. ConScape can form closed systems – acoustic cabins as well as open sets – partitions.

PL | ConScape to system aranżacji przestrzeni pozwalający wyodrębnić prywatną strefę potrzebną do pracy w skupieniu. Oprócz trwałej konstrukcji przy projektowaniu zwrócono uwagę na zastosowanie materiałów ekologicznych. Produkt zaprojektowany jest w taki sposób, aby móc stworzyć układy zamknięte – kabiny akustyczne oraz układy otwarte – ściany działowe.

DE | ConScape ist ein Raumteilersystem, das Privatsphäre schafft und somit konzentriertes Arbeiten fördert. Bei der Konzeptentwicklung wurde der Schwerpunkt nicht nur auf eine langlebige Konstruktion gelegt, sondern auch auf den Einsatz von nachhaltigen Materialien. Mit ConScape können sowohl geschlossene Konzepte wie Akustikkabinen als auch offene wie Trennwände realisiert werden.

FR | ConScape est un système d'aménagement d'espace permettant de créer une zone privée nécessaire pour travailler en toute concentration. En plus de sa construction durable, une attention particulière a été portée à l'utilisation de matériaux écologiques dans sa conception. Le produit a été conçu de manière à permettre la création de configurations fermées - des cabines acoustiques - ainsi que d'espaces ouverts - des cloisons amovibles.

# ConScape



# ConScape



1| ConScape closed set - S booth 2| ConScape closed set - L booth

"We designed ConScape as a complete solution to organize the workspace. We achieved its visual lightness by elevating the walls above the floor."  
-Studio Rygalik



1| ConScape closed set - M booth

ConScape





# ConScape



1| ConScape open set - C1 2| ConScape open set - C2 3| Idea S occasional table

# SafeSpot

EN | SafeSpot is a seating system embraced within modular acoustic walls. It creates a comfortable space for casual conversations, meetings or individual work. It provides the perfect environment for focused work by enhancing the acoustic properties of the workspace.

PL | SafeSpot to system siedzisk otulonych modularnymi ściankami akustycznymi. Jego zadaniem jest stworzenie komfortowej przestrzeni do rozmów, spotkań czy samodzielnej pracy i wyciszenia. Rozwiązanie sprzyja skupieniu poprzez zwiększenie walorów akustycznych przestrzeni biurowej.

DE | Das modulare Sitzsystem SafeSpot bietet dank einer akustisch wirksamen Abschirmung einen komfortablen Ort für Gespräche, Meetings, ungestörte Einzelarbeit oder auch für Entspannung. Das System verbessert die Raumakustik im Büro und schafft eine konzentrationsfördernde Umgebung.

FR | SafeSpot est un système de sièges enveloppés par des parois acoustiques modulaires. Son objectif est de créer un espace confortable pour les discussions, les réunions ou le travail individuel et la concentration. Cette solution favorise la concentration en améliorant les qualités acoustiques de l'espace de bureau.

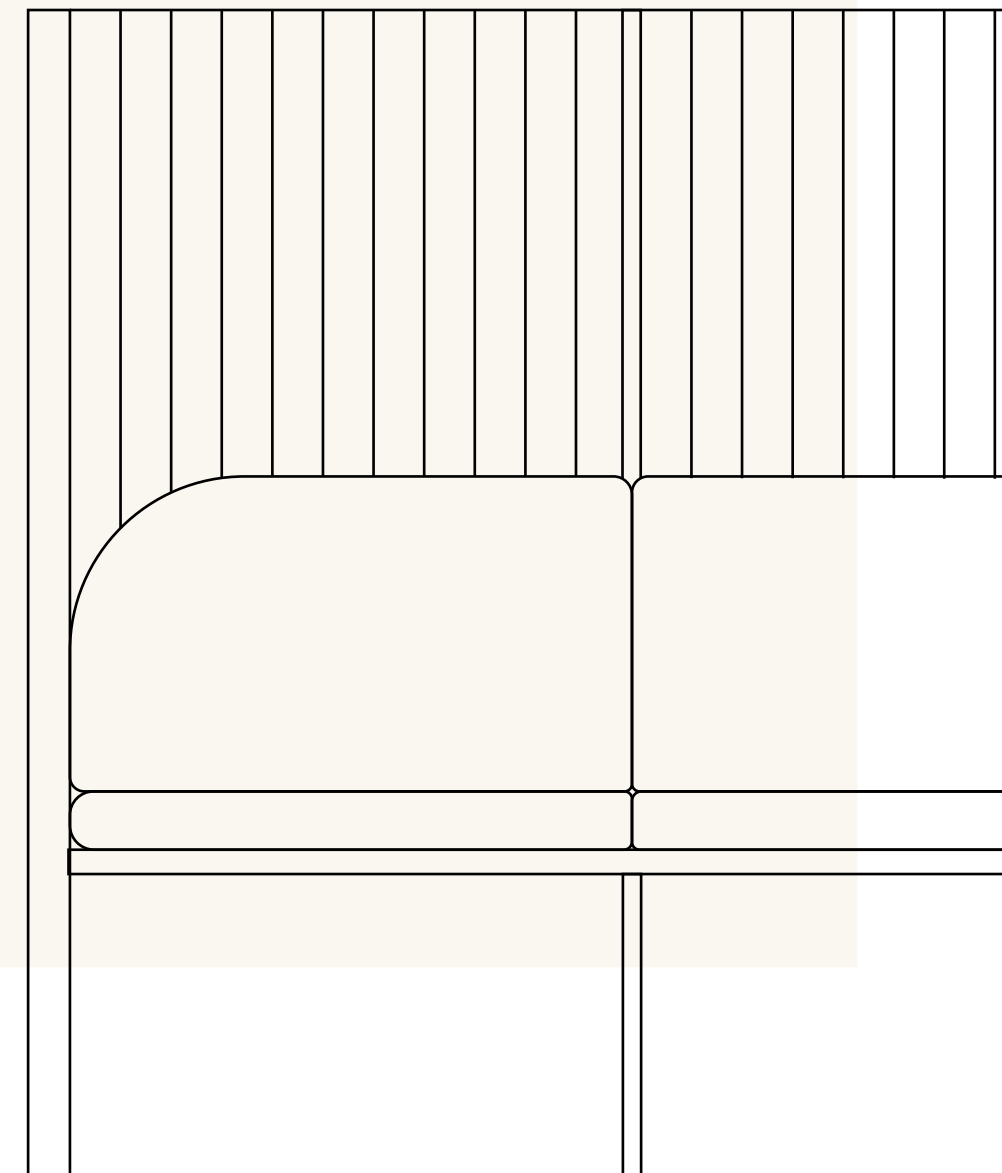

# SafeSpot



1

2



1

1| SafeSpot 4-person sofa 2| Idea S occasional table

"SafeSpot embraces you with acoustic comfort. We designed the seats to allow for various spatial compositions and configurations."  
-Studio Rygalik



1

1| SafeSpot 2-person sofa

# SafeSpot



EN | AcuStixx is a modular system of standalone partitions. It allows the creation of both closed spaces as well as acoustic space dividers. It offers a large selection of shapes and setups.

PL | AcuStixx jest modułowym systemem przegród wolnostojących. System pozwala stworzyć zarówno zamkniętą przegrodę jak i przepierzenie rozpraszające dźwięk, co stwarza większe możliwości w doborze kształtu i konfiguracji docelowych układów produktu.

DE | AcuStixx ist ein modulares System von freistehenden Trennwänden. Mit den Akustikelementen können sowohl geschlossene als auch offene, schalldämmende Raumteiler geschaffen werden, was verschiedene Formen und Aufstellungskonzepte realisieren lässt.

FR | AcuStixx est un système modulaire de cloisons autoportantes. Ce système permet de créer à la fois des cloisons fermées et des cloisons diffusant le son, offrant ainsi plus de possibilités dans le choix de la forme et de la configuration des agencements finaux du produit.

# AcuStixx

# AcuStixx



1

2

1| AcuStixx modular system of standalone partitions 2| Idea S occasional table

"AcuStixx was born with a vision to freely compose and organize the space. We arrived with an idea of sound-absorbing vertical soft 'blinds' that can be opened or closed as needed."  
-Studio Rygalik



1| AcuStixx modular system of standalone partitions 2| Lusso 1 occasional table



AcuStixx



ConScape

closed set - S booth

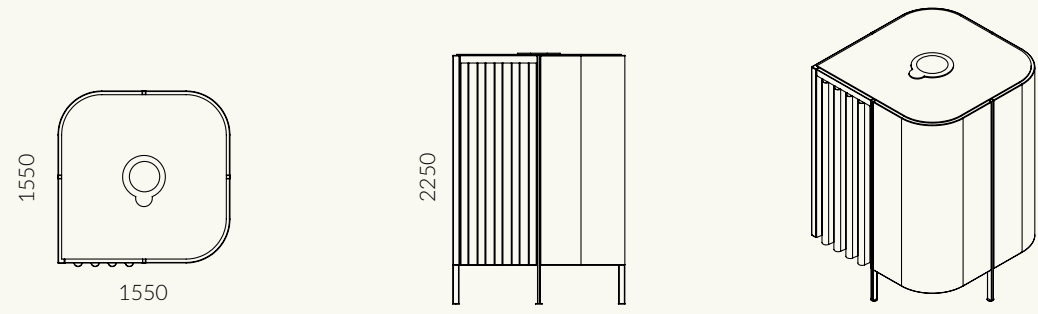

closed set - M booth

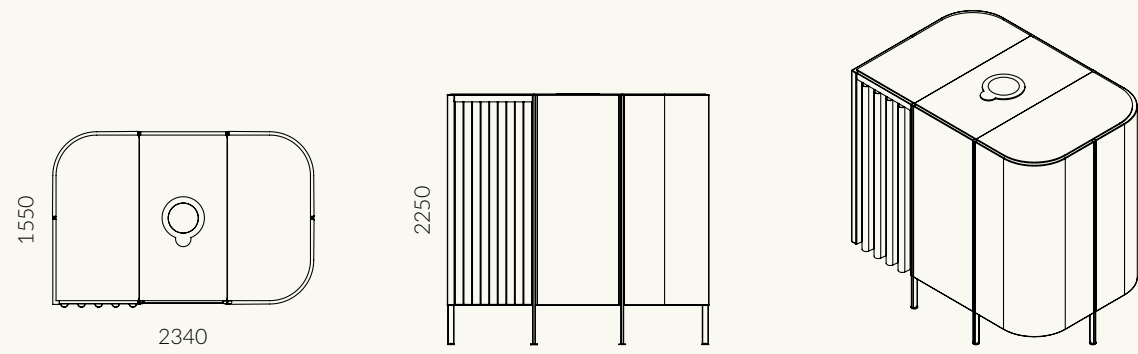

closed set - L booth

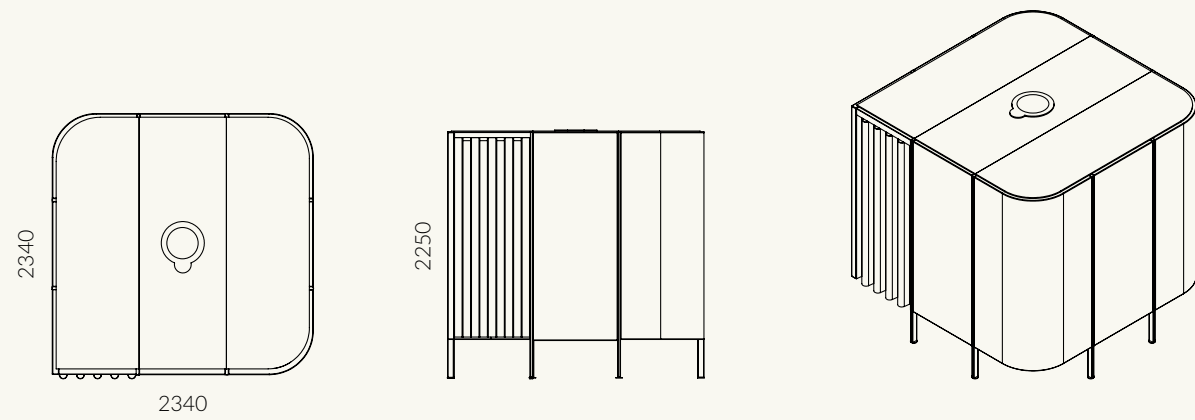

ConScape

closed set - XL booth

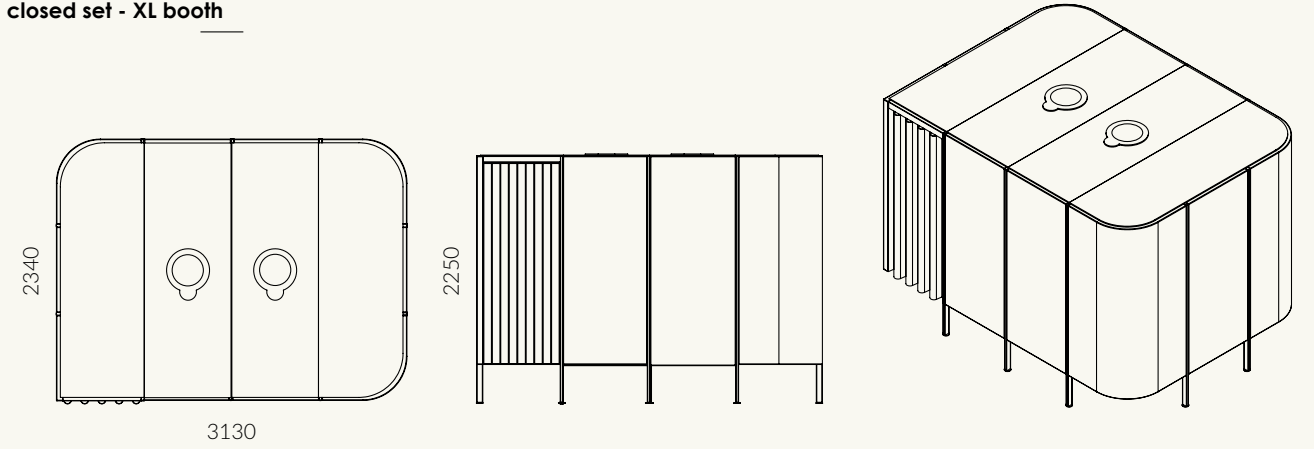

round wall-mounted table

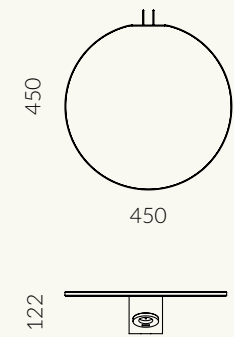

oval wall-mounted table

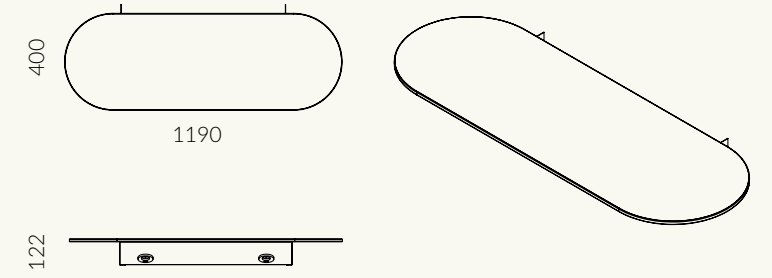

coat hook

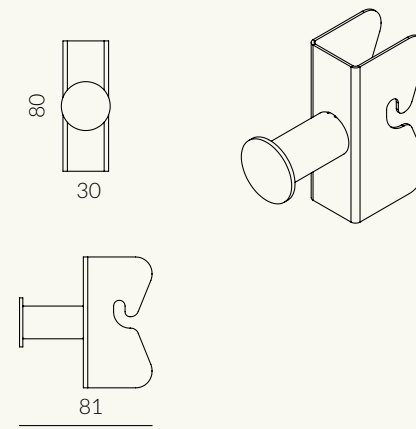

TV-holder

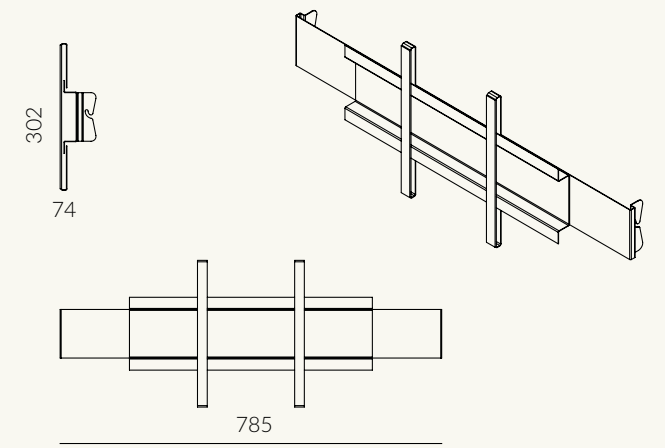

ConScape

open set - C1

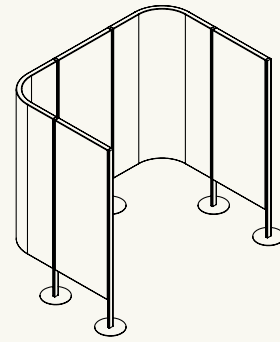
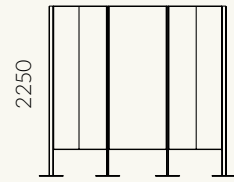
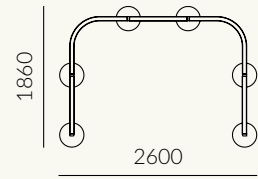

open set - C2

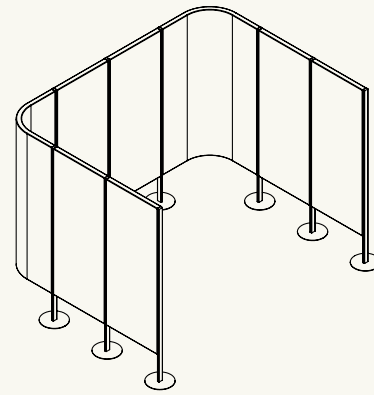
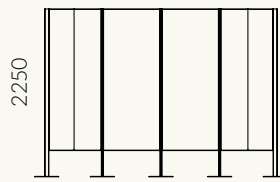
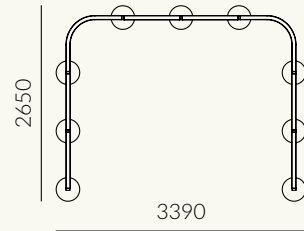

open set - S1

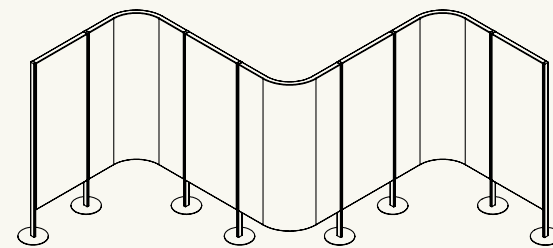
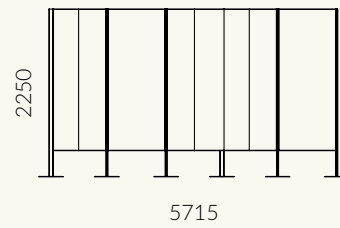
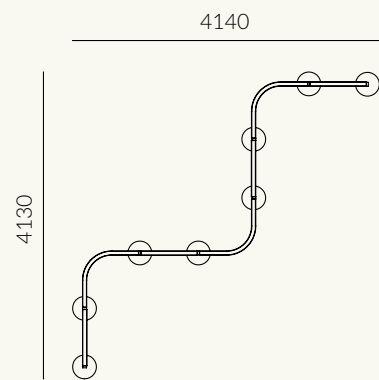

ConScape

open set - S2

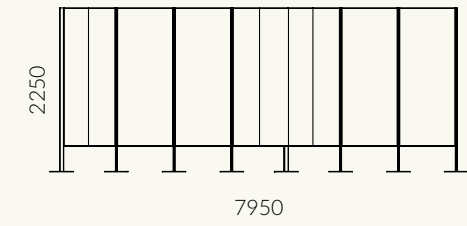
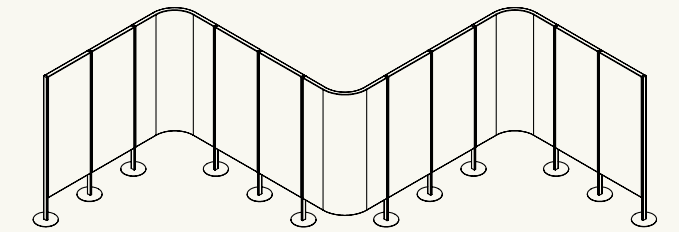
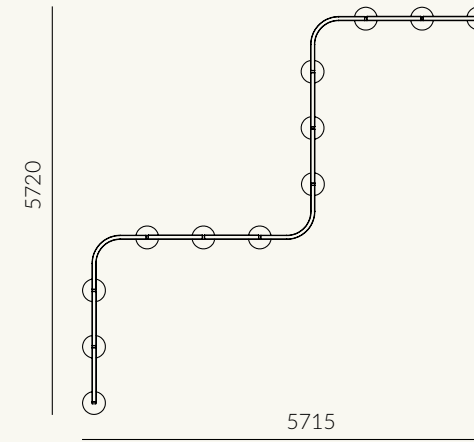

## SafeSpot

### 2-person sofa

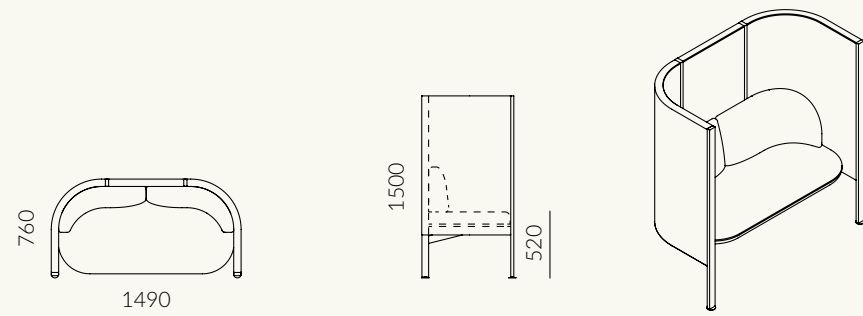

### 3-person sofa

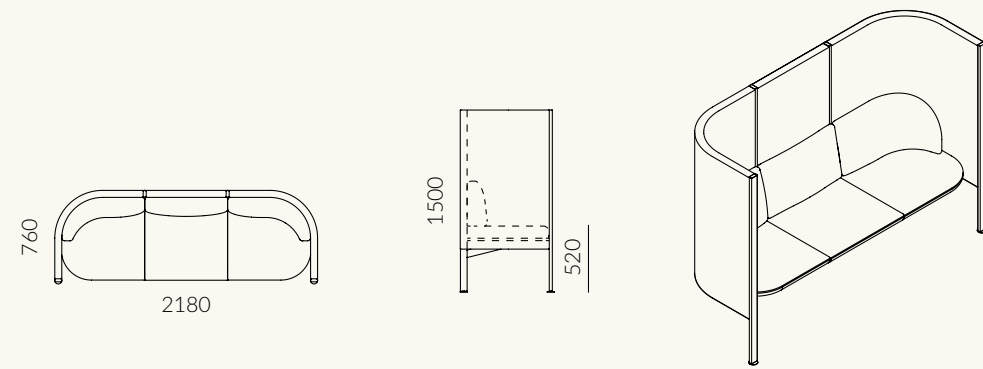

### 4-person sofa

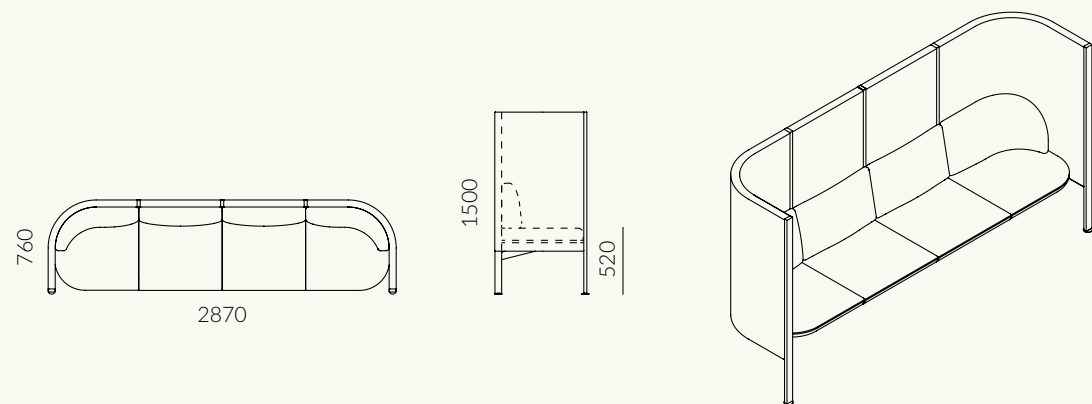

## AcuStixx

### first module

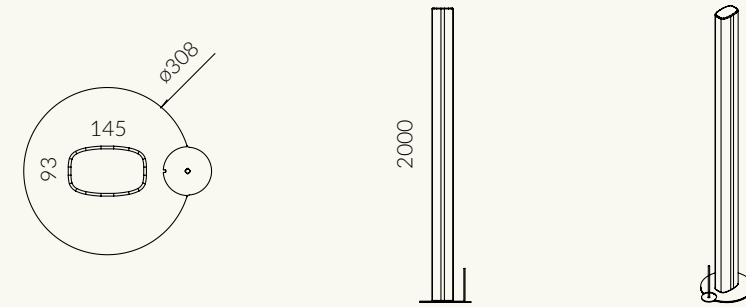

### last module

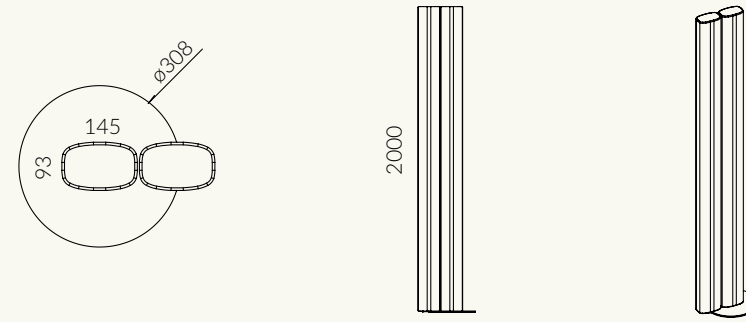

### middle module

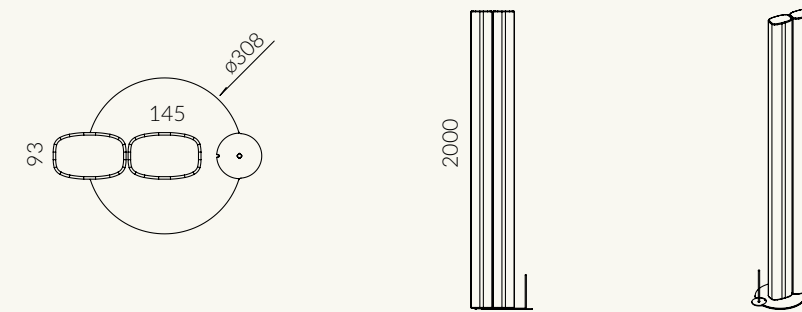

### extension module

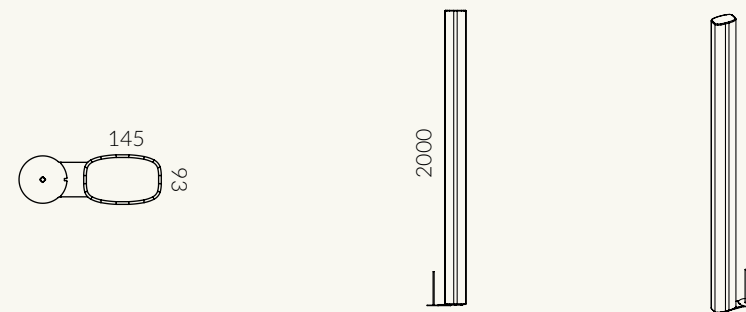

## AcuPro

### wall absorber

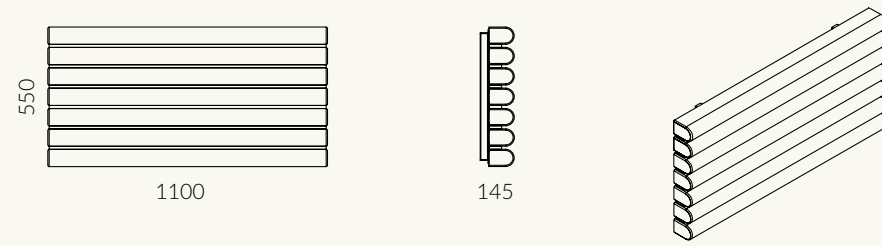

### extension module

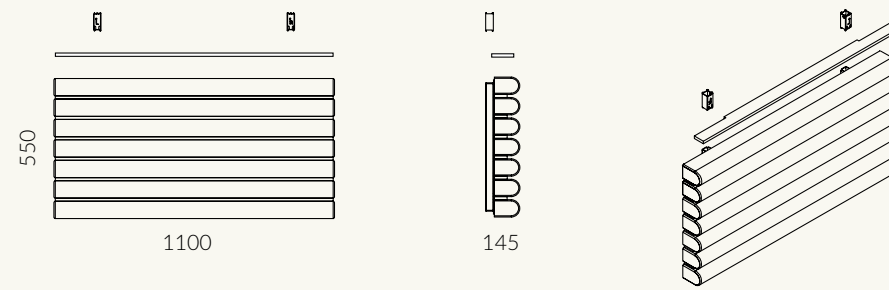

### shelf

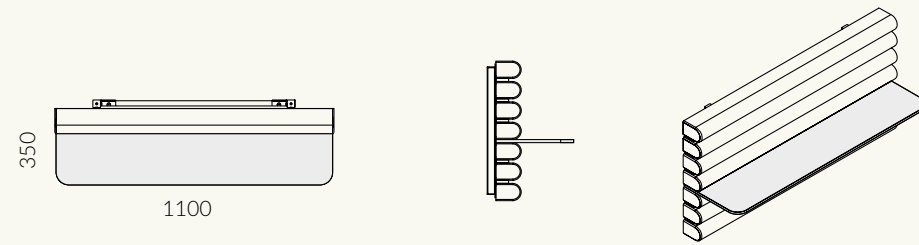

## CubiSound

### symmetric wall absorber

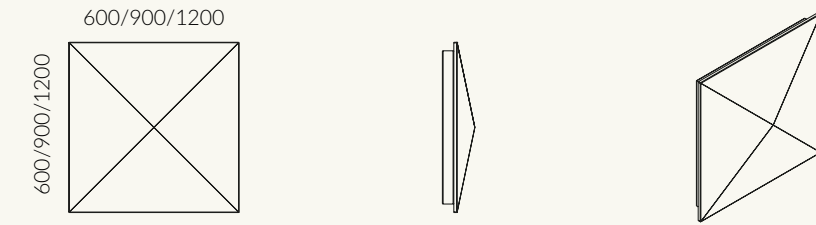

### asymmetric wall absorber

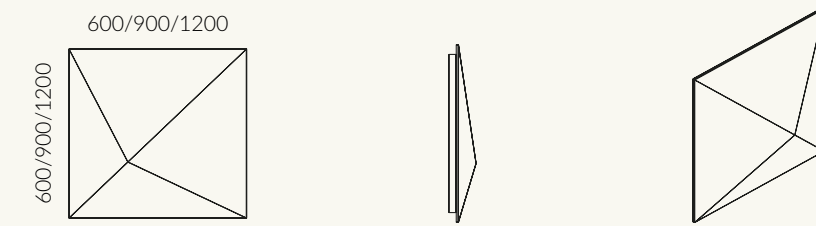

### symmetric ceiling absorber

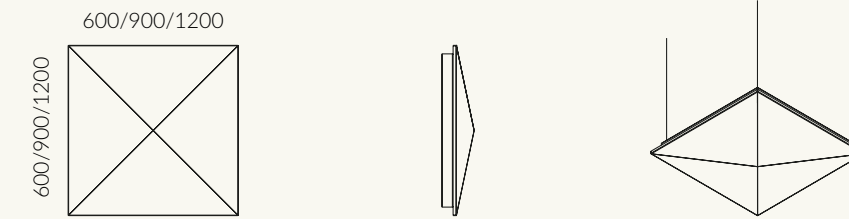

### asymmetric ceiling absorber

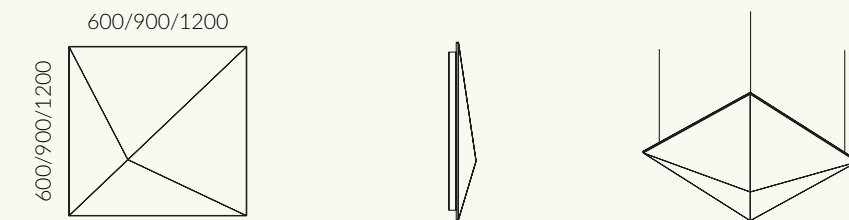

## DualSystem

### Rectangular wall panel / rectangular partition

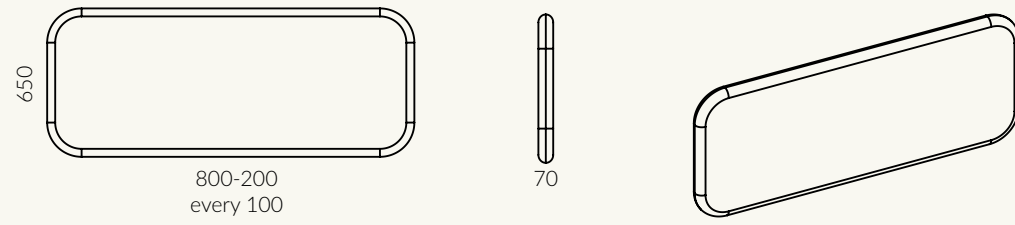

### Symmetric wall panel / symmetric partition

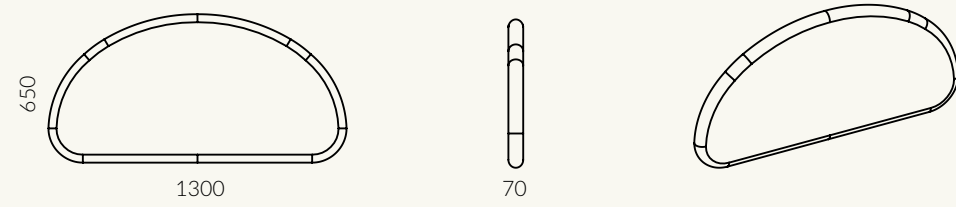

### Asymmetric wall panel / asymmetric partition

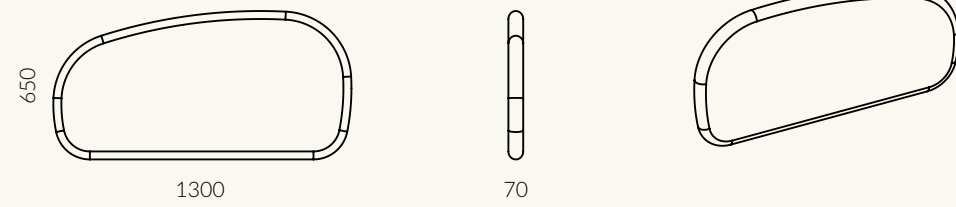

## DualSystem

### Desk bracket

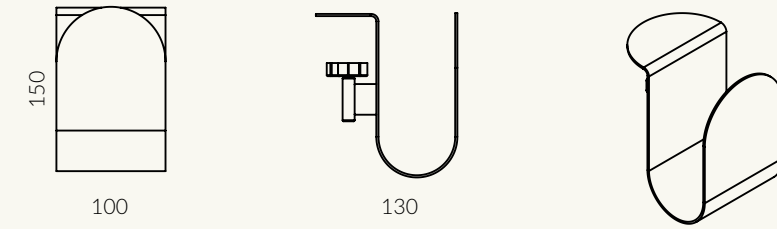

### Wall bracket

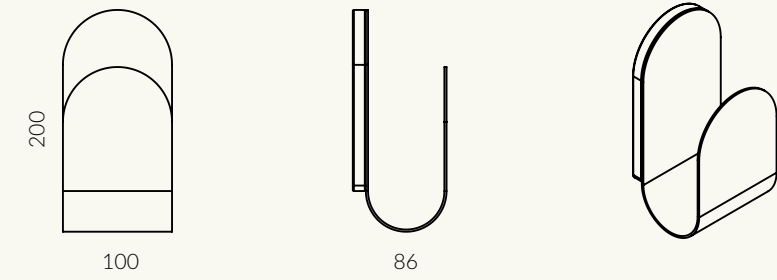

# AcuPro



EN | AcuPro is a system of acoustic panels with high sound absorption properties. The product combines advanced functionality with uncompromised aesthetics.

PL | AcuPro to modułowy system paneli akustycznych charakteryzujący się wysokimi parametrami dźwiękochłonnymi. Przy tworzeniu tego produktu skupiono się na połączeniu zaawansowanej funkcjonalności z wyrafinowanymi aspektami wizualnymi.

DE | AcuPro bietet ein modulares System von Akustikabsorbern mit hohen schalldämmenden Eigenschaften. Das Konzept legt den Fokus auf Verbindung von fortgeschrittener Funktionalität und raffinierter Optik.

FR | AcuPro est un système modulaire de panneaux acoustiques caractérisé par des performances acoustiques élevées. Lors de la création de ce produit, l'accent a été mis sur la combinaison d'une fonctionnalité avancée avec des aspects visuels sophistiqués.



AcuPro



1| AcuPro wall absorber



"With AcuPro we focused on meeting the highest acoustic standards with truly exceptional sound absorption properties - shaping soft geometries that reflect sound waves into precisely designed absorbing niches."

-Studio Rygalik



1| AcuPro wall absorber 2| AcuStix modular system of standalone partitions 3| Sirio occasional table 4| Variant compact desk with height adjustment

AcuPro



# CubiSound

EN | CubiSound acoustic panels enrich the workspace with fresh aesthetic value. Thanks to their geometry they absorb and diffuse the noises supporting concentration. It's a perfect solution for conference rooms as well as open spaces.

PL | CubiSound wzbogaci przestrzeń pracy o świeżą estetykę. Dzięki swojej geometrii absorbuje i rozprasza dźwięki wspierając skupienie. Jest idealnym rozwiązaniem do sal konferencyjnych, jak również do przestrzeni typu open space.

DE | Die Akustikabsorber CubiSound sorgen für optische Frische im Büro. Ihre unregelmäßige Oberfläche absorbiert und zerstreut Geräusche, was die Konzentration fördert. CubiSound ist die perfekte Lösung für Konferenzräume und Großraumbüros.

FR | CubiSound enrichit l'espace de travail d'une esthétique fraîche. Grâce à sa géométrie, il absorbe et diffuse les sons, favorisant ainsi la concentration. C'est une solution idéale tant pour les salles de conférence que pour les espaces de type open space.

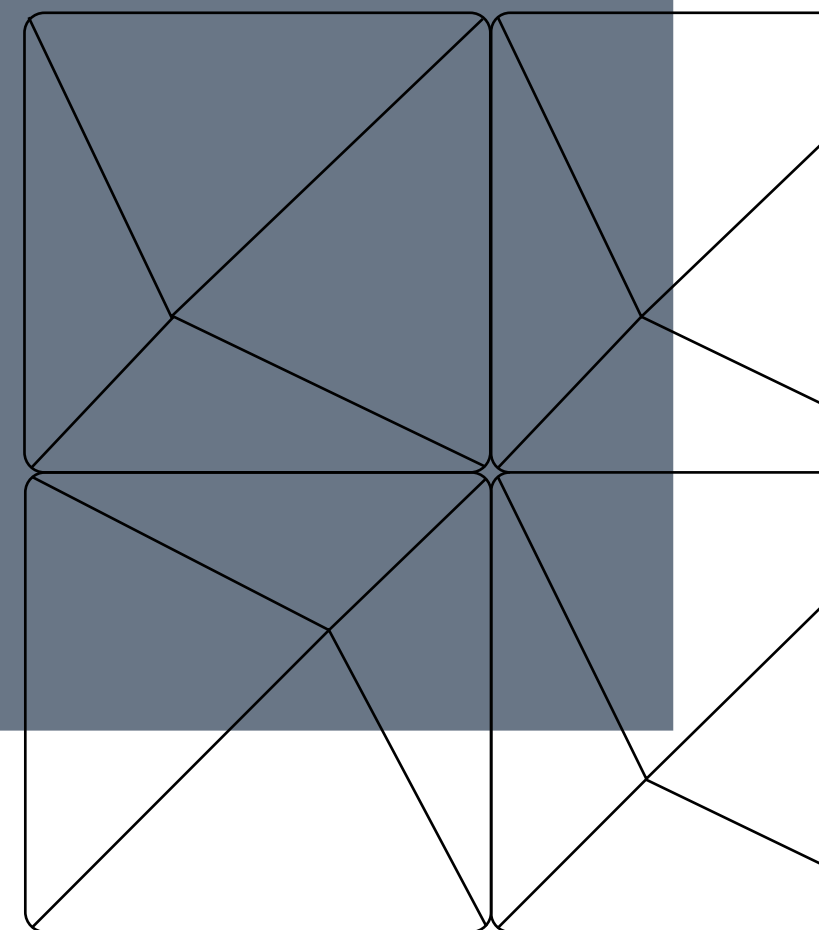

# CubiSound

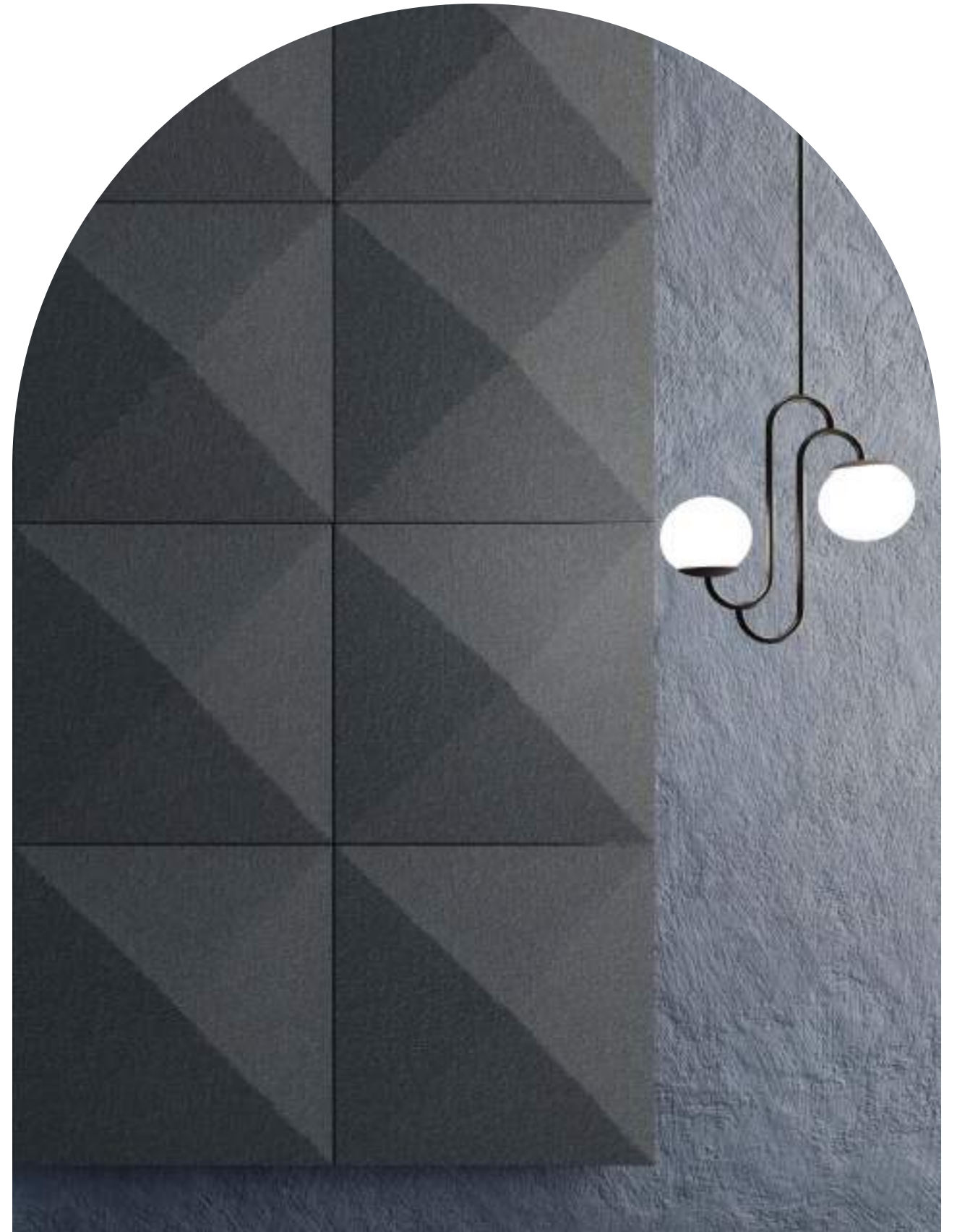

1| CubiSound wall absorber 2| Sirio conference table

"The geometry of the panels subtly referring to cubism paired with interesting color options make CubiSound enrich the space as contemporary art does."

-Studio Rygalik



1| CubiSound wall absorber 2| Lusso 1 occasional table

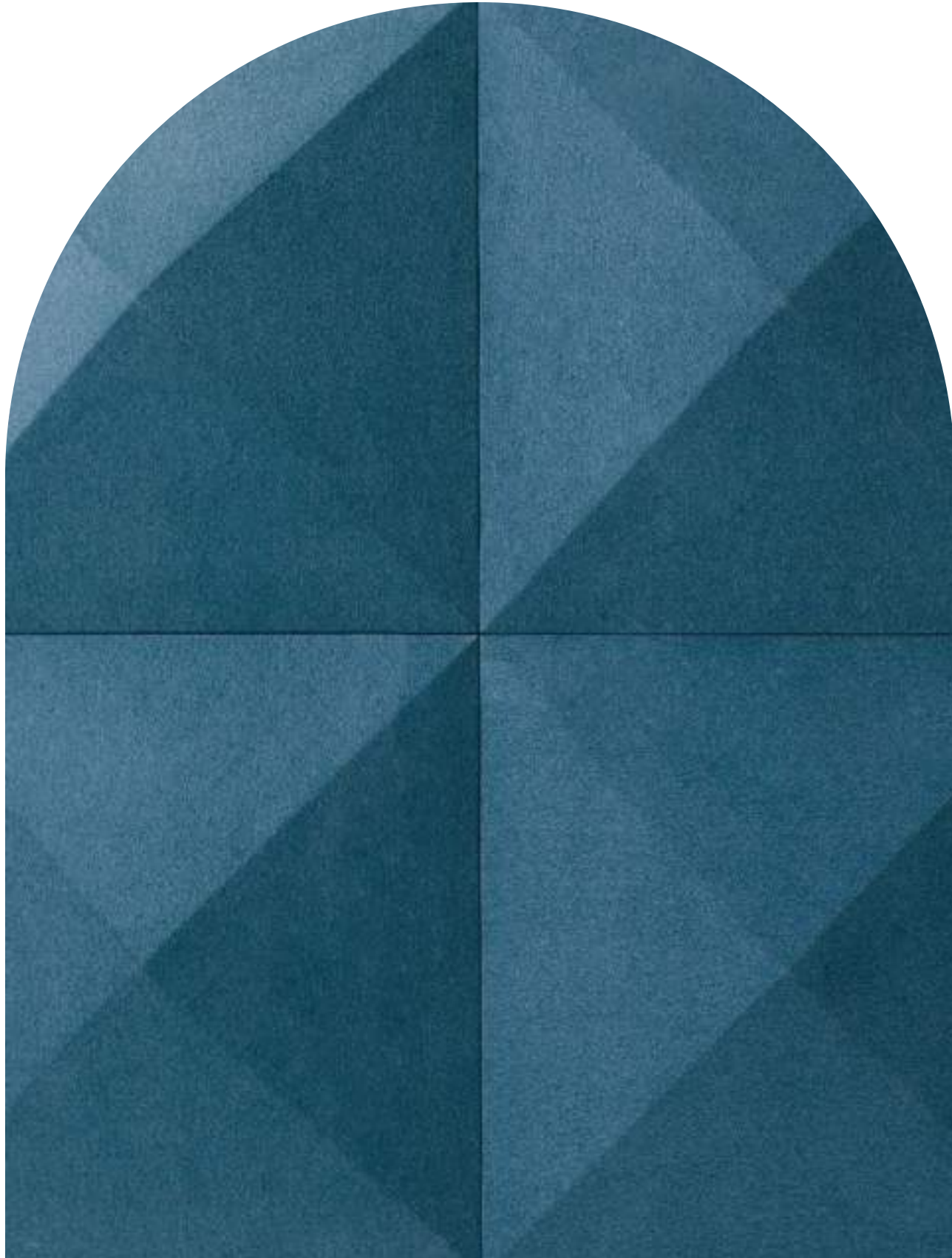

# DualSystem

**EN** DualSystem is a solution consisting of lightweight acoustic panels of different shapes that can be applied in two different ways: on the wall or on the desk. This gives you the freedom to configure the acoustic environment of your workspace. Mounting hooks for both wall and desk tabletop allow the panel to be freely inserted or repositioned. The collection includes a variety of panels in a diverse color range of dedicated fabrics.

**PL** DualSystem to rozwiązanie składające się z lekkich paneli akustycznych o różnych kształtach, które można aplikować na dwa różne sposoby: na ścianie lub na biurku. Daje to możliwość swobodnej konfiguracji przestrzeni akustycznej miejsca pracy. Haki mocujące do montażu zarówno na ścianie jak i na krawędzi blatu biurka umożliwiają swobodne wysunięcie lub włożenie panela. W kolekcji znajdują się różne kształty paneli w różnorodnej ofercie kolorystycznej dedykowanych tkanin.

**DE** DualSystem bietet leichte akustische Paneele in verschiedenen Formen, die als Wandabsorber oder Tischtrennwände am Arbeitsplatz eingesetzt werden können. Mit dieser Lösung lässt sich die Akustik in den Arbeitsräumen flexibel gestalten. Die Befestigungselemente sowohl für die Wandmontage als auch für die Schreibtische lassen die Paneele einfach einschieben und herausziehen. Die Kollektion umfasst verschiedene Formen von Paneelen in diversen Stofffarben.

**FR** DualSystem est une solution composée de panneaux acoustiques légers de différentes formes, qui peuvent être appliqués de deux manières différentes : sur un mur ou sur un bureau. Cela offre la possibilité de configurer librement l'espace acoustique du lieu de travail. Les crochets de montage permettent de fixer les panneaux aussi bien sur le mur que sur le bord du bureau, ce qui permet de les faire glisser librement ou de les insérer. La collection comprend différents modèles de panneaux dans une large gamme de couleurs de tissus.

# DualSystem

# DualSystem



1| DualSystem wall panel 2| Idea S occasional table



# DualSystem



"In the design of DualSystem, we focused on product versatility combined with ease of use to ensure that the acoustic comfort of the workspace can be freely configured.."

-Studio Rygalik

1| DualSystem wall panel 2| AXY-Line narrow executive showcase 3| DualSystem symmetric partition 4| O-eM rectangular top desk



Fabryka Mebli Biurowych MARO Sp. z o.o.

PL 62-052 Komorniki, Fabianowska 100

☎ +48 61 890 00 00

@ maro@maro.eu

 MARO Office Furniture  @maroofficefurniture

 MARO Office Furniture  MARO Office Furniture

Niniejsza publikacja nie stanowi oferty w rozumieniu prawnym. MARO zastrzega sobie prawo wprowadzenia zmian w ofertowanych meblach. Prezentowane kolory mogą odbiegać od rzeczywistości. Wszystkie wzory chornione są w Urzędzie Patentowym RP

*This publication does not constitute an offer in legal terms. MARO reserves the right to introduce changes to the offered furniture. Presented colors may differ from reality. All designs are protected by the Polish Patent Office.*

[maro.eu](https://maro.eu)

© MARO 04/24



Fabryka Mebli Biurowych MARO

[maro.eu](http://maro.eu)